

STRICTLY CONFIDENTIAL
FOR PHILIPS SERVICE DEALERS ONLY

●
 [COPYRIGHT 1938]

PHILIPS

SERVICE DOCUMENTATION

FOR RECEIVER TYPE

215 A

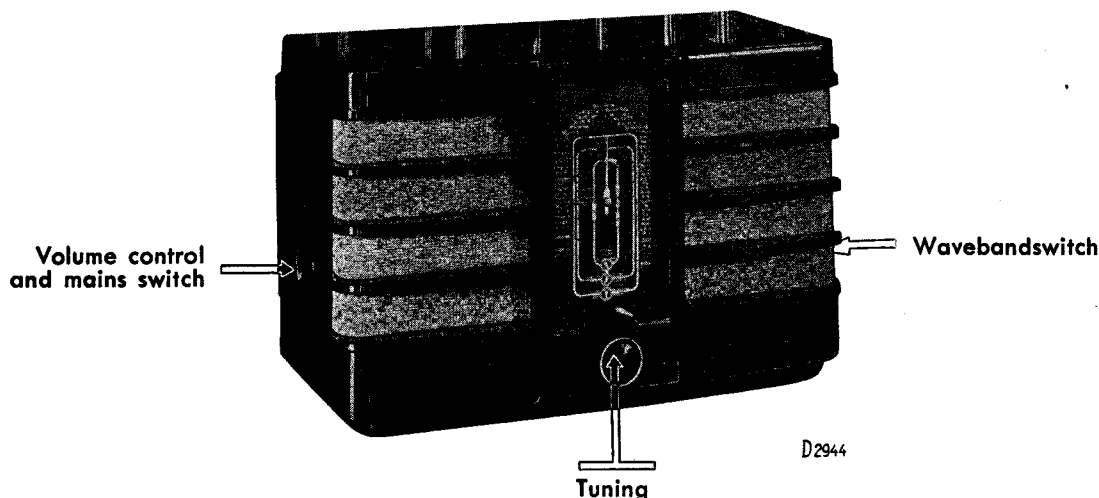

FOR A.C. FEEDING
 EXECUTIONS 215 A, 215 A-13, 215 A-25, 215 A-33

GENERAL DATA:

This superhet receiver is provided with:
 Seven tuned circuits.
 Bandpass filter pre-selection.
 Filter against second-channel interference.
 Delayed A.V.C.
 Permanently energised moving coil speaker (type 9648).
 Connection for gramophone pick-up.
 Voltage adapter with automatic indication on the rear panel, for voltages of 105-250 volts.

WAVE BANDS.

Short waves: 16,7- 51 m (18- 5.9 Mc/s)
 Medium „ : 198 - 585 m (1510-512 Kc/s)
 Long „ : 708 -2000 m (425-130 Kc/s)

KNOBS.

On left-hand panel: Volume control + mains switch
 On front panel: Tuning
 On right-hand panel: Waveband switch.

WEIGHT: 6.9 kg net (including valves).

DIMENSIONS: height: 25 cm
 width: 42 cm (including knobs)
 depth: 20 cm (including knobs)

Description of circuits.**A. H.F. part.****I. Long wave band.**

Aerial coil: S6 + S7.

1st bandpass filter circuit: S8 + S9, C15, C16, C7, C10 (coupled with aerial coil, inductively by coupling between S8 + S9 and S6 + S7, capacitively by C14).

2nd bandpass filter circuit: S10 + S11, C15, C16, C8, C11 (coupled with 1st bandpass filter by C15 + C16). (Coupled with the input grid of L1 via R14, to prevent parasitic oscillation).

Oscillator circuit: S14 + S16, C19, C20, C12, C9.

Reaction coupling coil: S15 + S17, inductively coupled with S14 + S16.

II. Medium wave band.

Aerial coil: S6.

1st bandpass filter circuit: S8, S30, C16, C7, C10 (coupled with aerial coil: inductively through coupling between S8 and S6, capacitively by S14).

2nd bandpass filter circuit: S10, S31, C16, C8, C11 (coupled with first bandpass filter capacitively by C16, inductively by coupling between S30 and S31). (Coupled with input grid of L1 via R14, to prevent parasitic oscillation).

Oscillator circuit: S14, C20, C31, C9.

Reaction-coupling coil: S15, inductively coupled with S14.

III. Short wave band.

Aerial coil: S12.

Input grid circuit: S13, C32, C8 (S13 is inductively coupled with S12). (Coupling with input grid of L1 via R14, to prevent parasitic oscillation).

Oscillator circuit: S18, C9 (coupled with 1st grid of L1 via C29).

Reaction coupling coil: S19, inductively coupled with S18.

IV. Image frequency filter: C17 and S30 with the 1st bandpass filter circuit.**B. I.F. part.**

I. I.F. transformer : S20, C21, S21, C22.

I.F. amplifier valve: L2 (AF 3).

II. I.F. transformer : S22, C23, S23, S24, C24

C. Detector.

Detector circuit : Anode detector (= 1st diode of L3), S24, (C25), R8, R10, cathode L3.

D. L.F. Amplifier.

From the volume control R10 the detected L.F. voltage is applied via C26 and R11 to the grid of L3, then amplified here and passed via the speaker transformer S25, S26 to speaker S27.

E. Automatic volume control.

The H.F. voltage on the anode of L2 is applied to the second detector diode of L3 via the capacity of two intertwined wires.

The detected D.C. voltage produced in this way on R5 is applied via R9, S21 to the input grid of L2 and via R9, R4, S11, S10, R14, to the input grid of L1, in which way the negative bias, and thereby also the amplification of L1 and L2 are regulated.

When the set is switched to the short wave band only the amplification of L2 is controlled.

The 2nd detector anode of L3 is made negative with respect to the cathode by the voltage drop across R13 + R15. In this way the automatic volume control only comes into operation when the strength of the incoming signal is above a certain value.

F. Feeding.

Feed transformer: S1, S2, S3, S4.

Anti-hum condenser: C38 (not in sets with transformers having separate windings).

Rectifier valve: L4 (AZ 1)

Smoothing filter: C1, R2, C2.

The positive voltages for the valves are taken from C2.

Voltages for L1:

Va : via S20.

Vg3,5: via R3; decoupled by C4.

Vg2 : via R3, (S17, S15, S19); decoupled by C4 (see also under automatic volume control).

Vg1 : voltage drop across R1; decoupled by C13.

Voltages for L2:

Va : Via S22.

Vg2: Via R3; decoupling by C4.

Vg1: Voltage drop across R7, decoupled by C6 (see also under automatic volume control).

Voltages for L3:

Va : taken from C1, via S25.

Vg2: from C2.

Vg1: voltage drop across R13.

Va (2nd detector anode): voltage drop across R13-R15; decoupled by C28.

ADJUSTING THE RECEIVER.

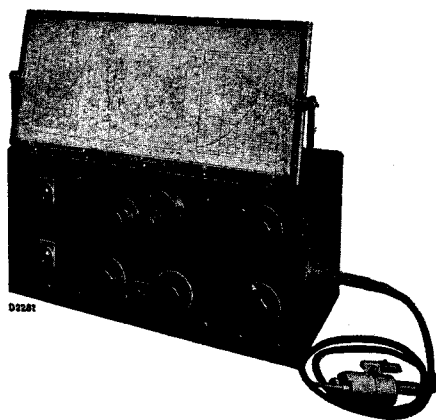

Fig. 1

For adjusting the receiver it is not necessary to remove it from its cabinet. By removing the back-plate all the points necessary for trimming are accessible.

Re-adjustment is necessary:

1. After changing coils or condensers in the I.F. or H.F. section.
2. When the set is not sufficiently sensitive or selective (see E-sheets).

When adjusting use:

1. Service oscillator GM 2880 (fig. 1).
2. Output indicator: Universal measuring apparatus 4256 or 7629.
3. A 15° gauge for establishing the relation between condenser position and dial.
4. Trimming plug-in key 6 mm, without metal parts.
5. Wax for fixing the trimmers.
6. A condenser of 32000 $\mu\mu\text{F}$.
7. A trimming transformer.

Always use the customer's valves when trimming. If during trimming the converter valve becomes defective then trim again (Pre-heat the new valve). Before proceeding to trim, the wax on the trimmers must be removed, whilst the trimmers must be turned sometimes up and down, in order to clean the screw-thread.

A. I.F. circuits.

1. Connect the output indicator to the speaker via a trimming transformer.
2. Apply a modulated signal of 128 kc/s to the 4th grid of L1 via a condenser of 32000 $\mu\mu\text{F}$.
3. Trim C24, C23, C22, C21 in succession to maximum output.
4. Repeat point 3.
5. Seal the trimmers.

B. H.F. and generator circuits.

1. Switch the set to the medium wave band.
2. Connect the output indicator to the speaker via a trimming-transformer.
3. Fit the 15° gauge with the aid of a mirror to the pin of the variable condenser. Turn

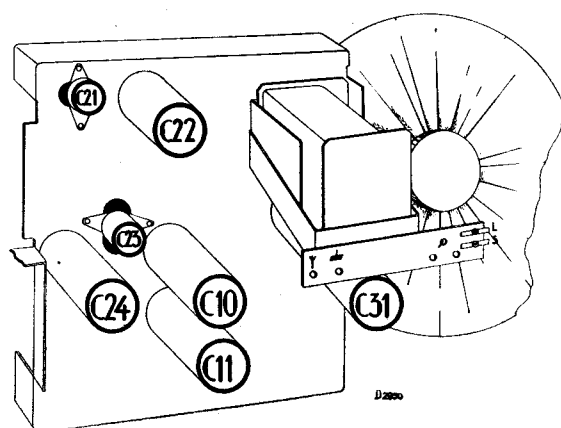

Fig. 2

the condenser against the gauge (minimum capacity).

4. Turn the volume control to maximum.
 5. Apply a modulated signal of 1442 kc/s to the aerial socket via a normal artificial aerial.
 6. Trim C31, C11 and C10 to maximum output.
 7. Repeat operation 6.
- C. Adjusting the dial.**
1. Switch the set to the medium wave band.
 2. Connect the output indicator to the speaker via a trimming transformer.
 3. Apply a modulated signal of 857 kc/s to the aerial socket.
 4. Tune the set.
 5. Adjust the pointer accurately to 350 m without turning the pointer spindle. If a new dial is to be fitted place it loosely under the pointer and act as indicated above, then:
 6. Check whether the pointer indicates the correct wavelength at the beginning and the end of the dial. If this is not the case shift the dial till the pointer indicates the right wavelengths.
 7. Nail the dial to the speaker board.

TRACING FAULTS.

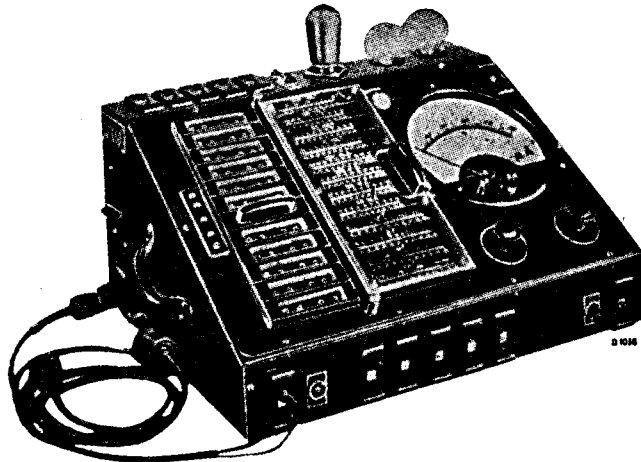

Fig. 3

For properly establishing defects a good measuring instrument is necessary; therefore always use the Universal Measuring Apparatus type 4256 (fig. 3) or 7629. To locate a fault it is necessary to take the set out of its cabinet. Do not unsolder a single connection before the defect has been located by measurement. The normal values of currents and voltages are mentioned between brackets. These values are measured with the measuring apparatus type 7629 or 4256.

I. Connect the set at the correct voltage and test its valves on the outdoor aerial or service-oscillator.

- a. If the set works normally leave it in operation and keep it in observation.
- b. If the set does not work at all, or badly, then:

II. Place a set of good valves from a properly functioning receiver in the set to be examined and if need be try another speaker. Faults in valves or speaker are thus eliminated or located.

III. Examine whether gramophone reproduction is possible.

- a. If reproduction is possible, then the fault lies in the I.F. or H.F. section (see under IV, C and D).
- b. If no reproduction is possible then the fault must be sought in the feed- or L.F. section (see IV, A, B and D).

IV. No radio and no gramophone reproduction.

A. Voltage on C2 abnormal (normally 225 volts).

1. Defect in the mains switch or voltage adapter.
2. Defect in the feed transformer.
3. C1, C2, C38 short circuited.
4. R2 interrupted.
5. Short circuit between the primary and the secondary of the speaker transformer.
6. Short circuit of S20 or S22 against earth.

B. Voltage on C2 normal (about 225 volts); no gramophone reproduction.

a. L3 has abnormal currents and voltages.
($V_a = 240$ V, $V_{g2} = 230$ V, $V_{\text{cathode}} = 9.5$ V, $i_a = 36$ mA, $i_{g2} = 5.4$ mA).

1. No anode current R13, R15, S25 interrupted.
2. Anode current too high; C28 short circuited.
3. R11, R12 interrupted.

b. L3 has normal currents and voltages.

1. R10, C26 interrupted.
2. C27, C30 short-circuited.

C. Gramophone reproduction, but no radio reception.

a. L2 has abnormal currents and voltages.

($V_a = 225$ V, $V_{g2} = <90$ V, $V_{\text{cathode}} = 2.4$ V, $i_a = 7$ mA, $i_{g2} = 2.4$ mA).

1. No anode current: R7, S22 interrupted.
2. Anode current too high: C6 short circuited.
3. No screen grid current: R3 interrupted, C4 short-circuited.
4. S21, R9, R5 interrupted.

b. L1 has abnormal currents and voltages.

($V_a = 225$ V, $V_{g3,5} = <90$ V, $V_{g2} = <90$ V, $V_{\text{cathode}} = 2.2$ V, $i_a = 2.4$ mA, $i_{g3,5} = 4.2$ mA, $V_{g2} = 1.7$ mA).

1. No anode current: S20, R1 interrupted.
2. Anode current too high: C13 short circuited.
3. No i_{g2} : S15, S17, S19, R3 interrupted; C4 short-circuited.
4. R14, S10, S11, S13, R4, R9, R5 interrupted.
5. R6 interrupted.

- c. L1 and L2 have normal currents and voltages, but no radio reception.
- N.B.** Always test the switching contacts of parts examined.
1. Apply a modulated signal of 128 kc/s to the control grid of L2 via a condenser of 32000 $\mu\mu\text{F}$ earth grid via 0.1 M.ohm).
No or only weak output.
R8 interrupted, C25 interrupted or short circuited.
S22, S23, S24, C23, C24 interrupted or short-circuited.
 2. Apply a modulated signal of 128 kc/s to the 4th grid L1 via a condenser of 32000 $\mu\mu\text{F}$ (earth grid via 0.1 M.ohm).
No or only weak output.
S20, S21, C21, C22 short-circuited or interrupted.
 3. A signal of 128 kc/s applied to the 4th grid is reproduced, but not an H.F. signal.
Oscillator not functioning.
 - a. In any of the wave bands.
R6 interrupted.
C9 interrupted or short circuited.
C4 interrupted.
 - b. Oscillator not functioning in one of the wavebands.
Oscillator coils or condensers of the respective waveband short-circuited or interrupted.
 4. Reproduction of an H.F. signal on the 4th grid of L1, but no reproduction of an H.F. signal to the aerial socket.
 - a. In none of the wavebands.
R14 interrupted.
C8 interrupted or short-circuited.
 - b. In one of the wavebands.
Coils or condensers of the pre-selection of the respective waveband short-circuited or interrupted.
- D. Radio and gramophone reproduction, but defectively.**
1. Reproduction too weak.
- Set out of adjustment — requires trimming.
C14, C15, C16, C42, S30, S31 interrupted.
2. **Distorted reproduction.**
Defective valve.
Defective speaker.
C30 interrupted.
 3. **A.V.C. not functioning.**
Wire capacity between anode L2 and anode of second diode of L3 not in order. (Two insulated wires twisted two turns about each other).
R5, R9, R4 interrupted.
C5 short-circuited.
 4. **Insufficient selectivity.**
Set out of adjustment — requires trimming.
C21, C22, C23, C24 interrupted or short circuited.
 5. **Microphonic effect.**
Fault in valves.
Fault in variable condenser.
Chassis touches the cabinet in another way than via rubbercushions.
Examples: Bracket of the lighting lamp touches the chassis.
C30 touches the cabinet.
Knobs or spindles touch the cabinet.
Pointer spindle touches speaker board.
 6. **Hum.**
C1, C2, C38 interrupted.
 7. **Crackling.**
Bad contact at a soldering point or in a switch.
 8. **Superheterodyning or croaking.**
One of the decoupling condensers interrupted.
C2, C4, C5, C6, C13, C25, C27, C28.
 9. **Resonances occur in the receiver.**
This may be caused by loose parts in the receiver such as springs, brackets, valve caps, etc. Resonating parts must be secured, if necessary with a piece of felt.

TRACING FAULTS BY THE "POINT-TO-POINT" SYSTEM

If a universal measuring apparatus type 4256 or 7629 is available the tracing of faults is greatly simplified by applying the "point-to-point" system. At the beginning this method is the same as that indicated in the E-sheets under points I and II. After this follows:

III. General examination according to the "point-to-point" system, i.e. measuring of resistance and capacity between the holder contacts and connection sockets, both with respect to each other and with respect to the chassis. In this way a fault and, with the aid of the circuit diagram, the defective part can be traced.

If need be compare with the E-sheets.

- a. Remove the mains flex from the plug socket.
- b. Remove all valves and place in the valve holder of the rectifier lamp a valve base with the contacts of filament and anodes interconnected. In this way, furthermore, the meter is protected against possible overloads on the smoothing condensers.
- c. Connect the universal measuring apparatus type 4256 or 7629 and set at resistance measurement (position 12). Lengthen the + pin of the measuring flex so that the contacts of the valve holder, etc. can easily be touched. Insert the other pin in the earth socket of the receiver.
- d. Measure the resistance between the points indicated in the point-to-point table and the chassis by touching the indicated contact by the + pin. Compare the meter deflection with the value in the table.

Note. P signifies: measure between the gramophone pick-up socket and earth, etc. 11/12 signifies: measure between points 11 and 12. 3 X 13 signifies: Measure at 3 positions of the waveband switch.

- e. Switch the measuring apparatus in succession on position 11, 10 and 9 and compare the readings.
- f. Set the universal measuring apparatus for capacity measurement (in succession on position 12, 11, 10 and 9). Compare the meter deflection with the value in the table.
- g. Remove the short-circuiting valve-base when measuring at the valve holder of the rectifier.

Important.

1. The values measured can vary about 10% with those given in the table, without this necessarily pointing to a defective part.
2. During resistance measurements of electrolytic condensers the leak current and with it the meter deflection drops during measurement. Now it may happen that the value found is much too high owing to a defective condenser; however, such a deviation also occurs when the set has not been in operation for a long time. Be careful therefore when judging electrolytic condensers!

Number code for valve-holder contacts..

The first numeral indicates the valve holder in accordance with the circuit diagram, the second one has the undermentioned significance:

- | | |
|---------|---|
| 1 and 2 | = filament |
| 3 | = control grid. |
| 4 | = contact for metallisation |
| 5 | = cathode |
| 6 | = extra grid (for instance 1st grid of octode, suppressor grid of penthode) |
| 7 | = screen grid |
| 8 | = anode |
| 9 | = extra grid (for instance 2nd grid octode). |

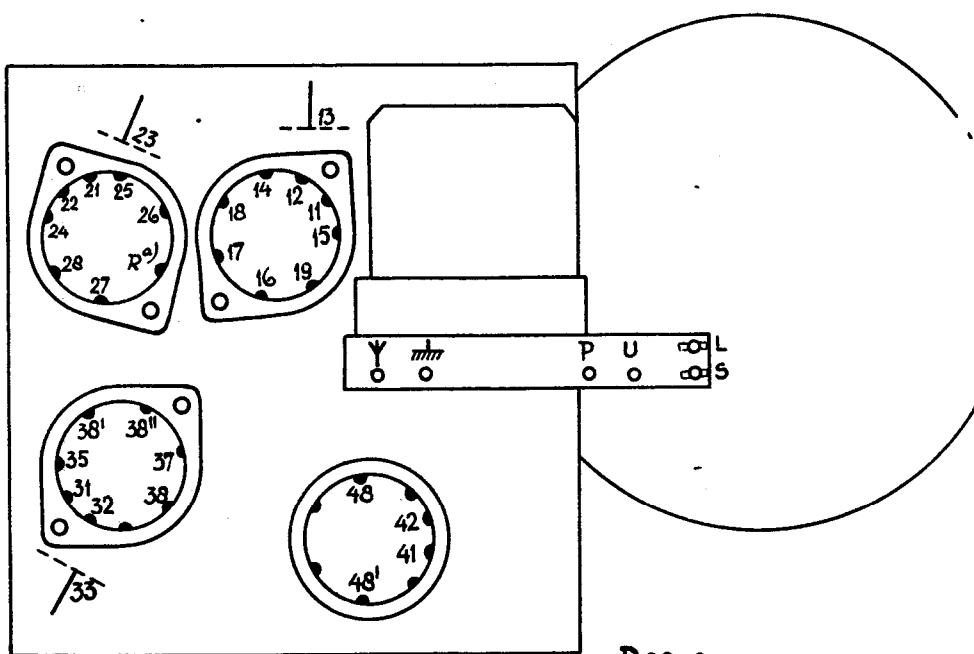

D2949

RESISTANCE

12	11/ 12	21/ 22	31/ 32	41/ 42	14	24	3 × Y			3 × 13							
	5	5	5	5	5	5	S. 90	M. 370	L. 465	S. 425	M. 500	L. 500					
11	15	23/ R	25	26	28	35	37	38									
	275	180	280	280	455	260	460	390									
10	17	18	3 × 19			27											
	265	455	S. 265	M. 265	L. 265	265											
9	U	3 × 13			33	38'	38''										
	220	S. 500	M. 65	L. 65	140	195	225										

CAPACITY

12	33																
	255																
11	R	48															
	170	265															
10																	
9																	

Measured with mains switched off.
 a) Concerning the point R see the circuit-diagram.

REPAIR AND CHANGING OF PARTS

General instructions.

1. After repair the course of the wiring and the position of the screening partitions must be brought into the original position.
2. Make sure at the same time that the wires are sufficiently far apart (at least 3 mm) from each other.
3. After repair replace in their original position spring washers, insulating material, etc.
4. As a rule rivets can be replaced by screws and nuts.
5. Moving parts may be slightly greased by means of a little pure vaseline.
6. Where necessary and possible, give contacts some mechanical pre-tension.
7. Solder as quickly as possible so that the parts themselves heat up as little as possible.
8. Condensers immersed in compound must be soldered at a distance of at least 1 cm from the compound, to prevent melting away of the compound and bad contact in the condensers. These condensers must be suspended free from the other wiring.
9. In view of the heat development of resistances, the latter must be mounted in such a manner that they do not touch any other parts.

Changing coils.

The coils are fixed to the chassis by means of tags which form part of the chassis. After the connections have been unsoldered and the tags have been bent back, the coil must be pulled carefully from the chassis. A new coil can be mounted with the aid of a pair of pliers.

If the tags have been broken off, the part must be fixed by means of a clamping plate.

Removing the set from its cabinet.

1. Remove the knobs.
2. Unscrew the back plate from below and fold upwards.
3. Loosen 7 screws with which the speaker-board is fixed to the cabinet and take the receiver out of the cabinet.
4. If the part in question is not yet accessible, then remove the chassis from the speaker board. For this purpose:
Remove the pointer.
5. Loosen the earth lead from the speaker board at the feed transformer.
6. Loosen the dial lighting lamp from the bracket.
7. Remove the four square nuts with which the chassis is fixed to the speaker board. The chassis can then be taken from the board.
If necessary:
8. Take the volume control off the speaker board.

Description of the waveband-switch.

The waveband switch consists of one or more units, an arresting plate for establishing the number of positions, spindles, springs, etc.

A unit (fig. 4) consists of a fixed ring, called the stator, a rotor, contact springs b which have to

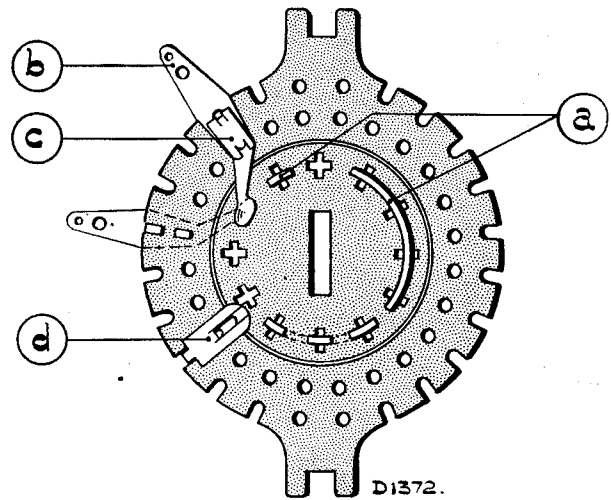

Fig. 4

be fixed to the stator by means of the clamps c, one or more springs d which keep the rotor in line with the stator and different types of contact pieces and connecting strips a.

The stator is provided with 24 holes placed in a circle. On the stator side a maximum of 12 contact springs can be attached; between the springs an opening is always left for fixing the contact springs of the other side, so that on both sides of the stator totally 12 contact springs can be fixed.

System for drawing the diagram of the switch.

In order to give a clear idea of the wavelength switch in the circuit diagram we are giving below a short explanation.

The contact springs on the stator side facing the arresting plate are indicated as open circles in the outer circle. Where there is no contact spring a black dot has been drawn. In all, therefore, 12 circles can be drawn in the outer circle.

In the inner circle 12 circles can also be drawn which indicate the contact spring on the other side of the stator. The interconnecting strips on the rotor side facing the arresting plate are indicated by continuous lines close to the outer circle; those on the other side of the rotor as a dotted line close to the inner circle, whilst contact pieces are shown as a short line between the inner and the outer circle.

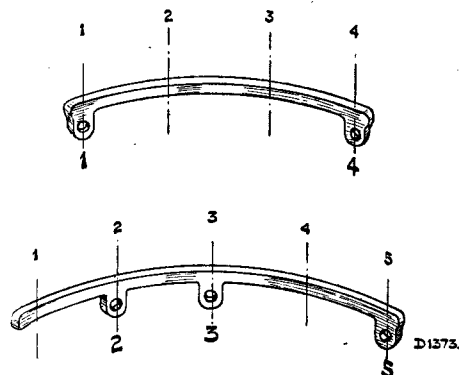

Fig. 5

The rotor contacts cover one or more holes and on one side all form part of a circle. The contacts are provided with tags which fit into the holes of the rotor and with which the contacts are fixed. This is done by pressing them together with a pair of smooth flat pliers. The pressed tag can also serve for contact on the other side. It is therefore important to make sure that the tag is pressed together in such a way that it is properly flat.

Description of the interconnecting strips in the list of parts.

The connections (fig. 5) can be made in many ways and a special method has been worked out to show clearly the type of connecting strip referred to. The strip is seen from the centre of the circle of which it forms part. The first figure indicates the number of holes covered, whilst the other figures show in which holes a tag comes, calculated from left to right. Thus, 4.1.4. indicates that 4 holes are covered and that, beginning from the left, holes 1 and 4 are used for fixing and also for contact on the other side.

5.2.3.5 means that 5 holes are covered and that holes 2, 3 and 5 are used for fixing and contacts on the other side. The strips are indicated in this manner in the parts-list, in which way it is possible to immediately find the code number of the required interconnecting strip.

The contact springs of the stator must also be fixed by the service man himself with the aid of clamps which can be done with the same pair of pliers.

Repairing the wavelength switch.

1. Unscrew the stopping device from the chassis and remove it, taking along at the same time the flat spindle that drives the switching segments.
(Take note of the position of this spindle and of the rotors and stators, so that they are not given half a turn when being inserted).
2. Unsolder the wires of the respective stator segment.
3. Unbend the tags by which the stator is fixed to the chassis. The stator can then be removed with the rotor and is easy to repair.

EXCHANGING THE VARIABLE CONDENSER.

Two kinds of variable condenser are used, viz, one of open construction and the other of closed construction. They are distinguishable from each other by the fact that the first kind has a casing closed on three sides, whilst the second kind is open on all four sides. For replacement only the "open" condenser is supplied. When a "closed" condenser has to be renewed three new toggles and a new fixing brace are required (see list of parts).

Replacement of a "closed" condenser by an "open" one is effected in the following way:

1. Remove the set from the cabinet.
2. Loosen the chassis from the loudspeaker panel.
3. Unscrew brace A (fig. 9) and bend it aside.
4. Remove the driving drum.
5. Unscrew the plug socket plate.

6. Unsolder the connecting wires of the variable condenser.
7. Unscrew from the chassis the brace by means of which the condenser is fixed to the chassis.
8. Unsolder the condenser from the chassis and remove it.
9. Fix a new variable condenser with 3 toggles to the new fixing brace.
10. Fit the new fixing brace to the chassis.
11. Solder the electric connections to the new condenser.
12. Fix the driving drum to the condenser (check, by turning the driving spindle, whether the condenser can be turned completely in and out; if not turn the drum on the condenser spindle).
13. Turn the condenser to maximum. Fix brace A (fig. 9) to the chassis. When doing so the spring on the pointer spindle must be given one turn (give the cog wheel one turn in clockwise direction).
14. Remove the metal brace on the back of the plug socket plate (file away the rivet) and fix the plug socket plate to the condenser brace.
15. Fix the chassis to the speaker panel and reinsert the set in the cabinet.

Renewal of pointer spindle, small spring on pointer spindle, driving drum and spring on driving drum.

1. Take the set out of the cabinet.
2. Remove the chassis from the loudspeaker panel.
3. Unscrew the brace A (fig. 9) and bend it a side.

It will further be clear how the above parts must be removed.

When mounting the driving drum again make sure that the condenser can be turned entirely in and out, if not turn the drum on the condenser spindle. When fixing brace A (fig. 9) the spring must be tightened one turn on the pointer spindle while the condenser is in maximum position. For this purpose the cogwheel on the pointer spindle must be given one turn in clockwise direction.

LOUDSPEAKER TYPE 9648.

Defects.

1. No reproduction: short-circuit or interruption in voice-coil.
2. Reproduction too weak and distorted: coil jammed.
3. Rustling: dirt in the air-gap, distorted coil, injured cone or too close connections.

Important.

1. When repairing take care for dust and iron-parts.
2. The front and rear plates may not under any circumstances be pulled off from the magnet.
3. Replace dust-cover after repair.

Centring the cone.

This can be done with 4 pertinax calipers which can be inserted between the coil and the core. A new cone can be centred with 4 calipers and fixed with a clamping ring with incisions.

LIST OF PARTS AND TOOLS

When ordering parts always state:

1. Code number
2. Type number of the set
3. Description of the part.

Fig.	Pos.	Description	Code number	Price
6	1	Cabinet (colour code 038)	23.660.435	
		Cabinet 215A-33	28.246.100	
6	2	Loudspeaker cloth	06.601.140	
6	4	Knob of volume control (colour code 038)	23.610.980	
6	3	„ „ waveband switch (do.)	23.611.030	
6	5	Knob for tuning	23.611.063	
6	6	Pointer	28.945.272	
6	7	Screw for fixing the pointer	07.579.710	
6	8	Spindle of pointer with cogwheel	25.873.470	
6	9	Cover plate behind the station-name dial	28.258.340	
		„ „ „ „ „ „ 215A-13	28.258.330	
6	10	Pressure spring behind pos. 9	28.731.150	
6	11	Glass window	28.340.442	
		Glass window 215A-33	28.341.120	
6	12	Rubber plug behind pos. 11	28.479.801	
6	13	Station-name dial (see below)	28.712.753	
		„ „ „ (Poland)	28.713.172	
		„ „ „ (Mediterranean and Portugal)	28.712.764	
		„ „ „ (Ireland)	A1,890.190	
		„ „ „ (for Oversea)	A1,890.480	
6	14	Driving spindle	28.621.262	
		Driving spindle 215A-33	28.622.230	
7	15	Drum	23.687.070	
7	16	Spiral spring on drum	28.740.662	
7	17	Lighting lamp holder	08.515.210	
7	18	Rubber tulle	25.655.951	
7	19	Valve hood	28.838.741	
7	20	Valve cap	28.906.023	
7	21	Rubber tulle	25.655.690	
7	22	Valve base for rectifier valve	28.226.100	
7	23	Plug socket plate	28.874.353	
7	24	Plate with pins	25.873.480 ¹⁾	
		„ „ „	25.873.490 ²⁾	
7	25	Brace for fixing pos. 24 to the power transformer	28.070.330 ¹⁾	
		Rear panel	28.402.824	
		Rear panel 215A-33	28.404.411	
		Marking disc	28.713.271	
		Setting screw 4 × 7 mm.	07.854.070	
		Spring round the pointer-spindle	28.760.251	
		Rotorcontact 1—1	28.904.161	
		„ 2—2	28.904.390	
		„ 3—2	28.904.211	
		„ 2—1	28.904.260	
		Clamping Ring with incisions for loudspeaker	25.873.410	
		Paperring for loudspeaker	28.452.690	

¹⁾ for power transformer with separate windings

²⁾ for power transformer with one coil.

Fig.	Pos.	Description	Code number	Price
		When replacing a condenser of the "closed" construction by one of "open" construction (see G sheets) the following parts are required:		
		1 variable "open" condenser (vide list of condensers)		
		1 brace	28.084.771	
		2 braces (toggles)	28.084.750	
		1 brace (toggle)	28.084.760	
		3 cylindrical screws 4 × 6 mm	07.804.060	
		3 Spring washers 4 mm.	07.041.400	
		TOOLS		
1		Service oscillator	GM 2880	
3		Universal measuring instrument	GM 4256	
		Universal and valve measuring instrument	GM 7629	
		15° gauge	09.991.741	
		Insulated plug-in key 6 mm.	M 646.565	
		Trimming transformer	09.992.220	
		Centring gauge for speaker	09.991.530	
		Lever for fixing coils	09.991.560	
		Clamping plate for fixing coils	28.080.870	
		Sealing wax	02.851.360	
		STATION-NAME DIALS		
		When ordering station-name dials always mention the code number indicated in the corner of the dial.		

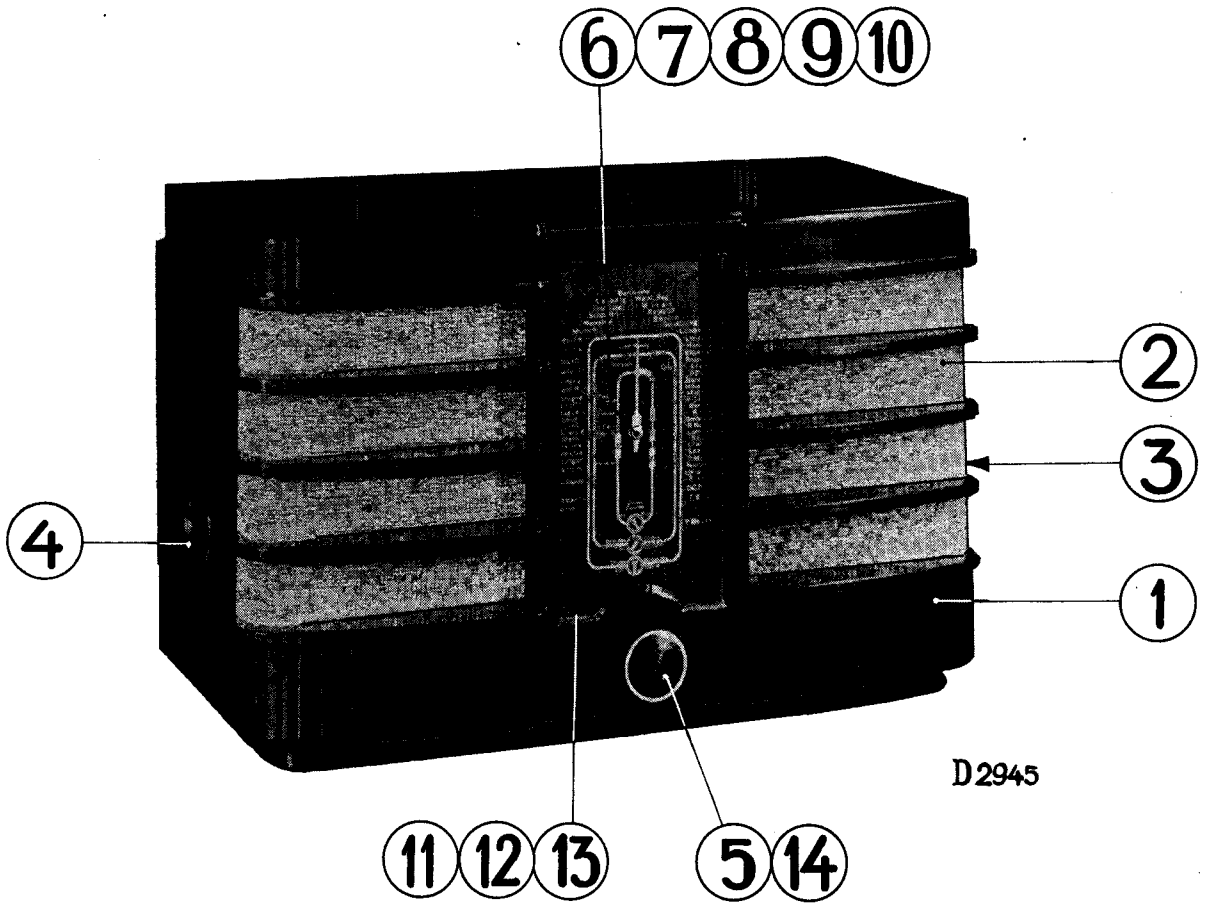

D2945

Fig. 6

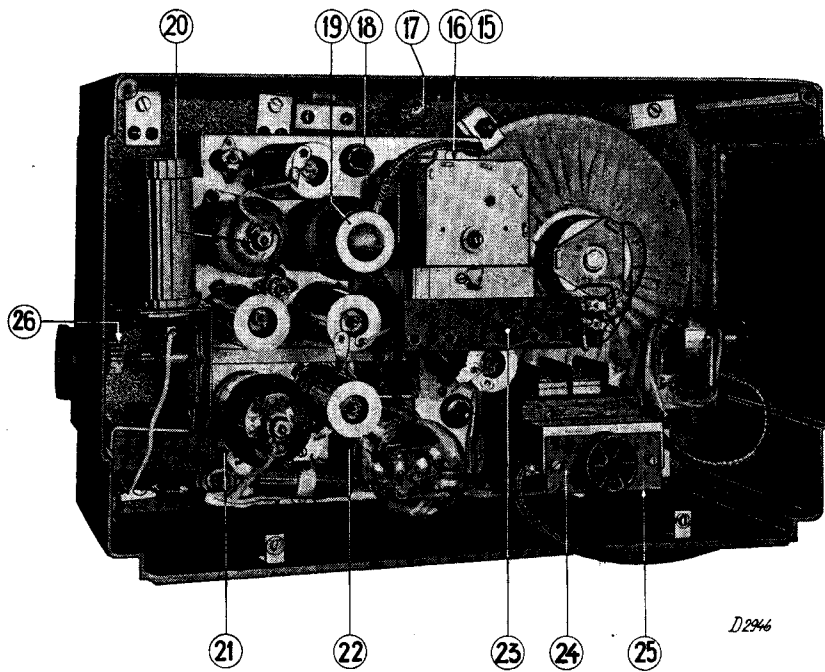

D2946

Fig. 7